

KARNATAKA GRAMEENA BANK

INVITATION TO TENDER

ONLY FOR EMPANELLED VENDORS (REFER ELIGIBILITY CLASS BELOW)

OF

KARNATAKA GRAMEENA BANK

TENDER FROM ANY OTHER PERSON/BIDDER WILL BE SUMMARILY REJECTED

INVITATION, GENERAL INFORMATION, T & C, LIST OF APPROVED MATERIAL,

SCHEDULE & PLAN FOR INTERIOR FURNISHING OF

**ANNEX BUILDING OF HEAD OFFICE-ANNEX AT
DHARWAD**

TENDER CLASS: A

(Contractors of below the above mentioned class are not eligible to participate for this tender)

TENDER NO.: G A / I F / 0 5 /26-27

NAME OF THE VENDOR:

.....

ADDRESS:

.....

(Name and address of Empanelled vendor to be filled by the vendor)

SEAL & SIGNATURE OF TENDERER

NOTICE OF INVITATION TO THE TENDER

To,

M/s

.....

.....

MOB:

(Name and address of Empanelled vendor to be filled by the vendor)

Sealed tenders are invited from empanelled Vendors for
“INTERIOR FURNISHING AT ANNEX BUILDING OF HEAD OFFICE-ANNEX AT DHARWAD”

BID TYPE: SINGLE ENVOLOPE

Earnest Money Deposit	:	NIL
Period of completion	:	3 Weeks from the date of Work order
Last date, time and place for Submission of tender	:	On or before 09.06.2026 to The General Manager , GA Wing, Karnataka Grameena Bank, Head Office, #32, Sanganakal Road, Gandhi Nagar, BALLARI - 583 103.
Date of opening of tender	:	10.06.2026

The Bank will not be bound to accept the lowest tender and reserves the right to accept or reject any or all the tenders without assigning any reason whatsoever.

Sd-

GENERAL MANAGER,

GA WING, KGB, HO, BALLARI

Date: 25.05.2026

SEAL & SIGNATURE OF TENDERER

1. GENERAL INFORMATION

YOU ARE REQUESTED TO FULLY UNDERSTAND THE CONTENTS OF TENDER BEFORE SUBMITTING BIDS.

NAME OF THE WORK	INTERIOR FURNISHING WORK AT ANNEX BUILDING OF HEAD OFFICE-ANNEX AT DHARWAD
TIME FOR COMPLETION	3 WEEKS FROM THE DATE OF ISSUE OF WORK ORDER
DATE OF ISSUE OF TENDER	25.05.2026
LAST DATE FOR SUBMISSION	09.06.2026, BEFORE 05.00 PM, IN SEALED COVER
Tender Document Fee	NIL
EMD	NIL
WHOM TO SUBMIT	The General Manager , GA Wing, Karnataka Grameena Bank, Head Office, #32, Sanganakal Road, Gandhi Nagar, BALLARI - 583 103
TIME & PLACE OF OPENING	10.06.2026, At the above address

Note: Karnataka Grameena Bank will not take any responsibility for any delay due to any reason in submitting the tender documents at the specified place. Any submissions after last date will be rejected.

Bids should be submitted within the due date to the below mentioned address and over script writing on the sealed cover should contain the following:

“Tender for Interior furnishing at ANNEX BUILDING OF HEAD OFFICE-ANNEX AT DHARWAD”
And has to be submitted to the following address:

**“The General Manager ,
GA Wing, Karnataka Grameena Bank, Head Office,
#32, Sanganakal Road, Gandhi Nagar, BALLARI - 583 103”**

This tender document contains following parts:

1. General information (this page)
2. Terms & conditions of the contract
3. List of approved materials
4. Interior furnishing plan (Available on Bank’s website)
5. Bill of Quantity (BOQ) (Available on Bank’s website)

DATE:

PLACE:

SEAL & SIGNATURE OF TENDERER

2. TERMS AND CONDITIONS OF THE CONTRACT

1. You should inspect the site, before submitting the tender and should understand the nature of works to be carried out.
2. The work should be undertaken as per the tender specifications & directions of the authorized Bank's representative. The Bank may or may not accept the lowest or any other tender and having the right to reject any or all the tenders without assigning any reason. Overwriting tender documents without authentication will be rejected.
3. Canvassing in any form will be a disqualification.
4. The vendor shall not be permitted to submit tender for works in the Bank in which his near relative is posted as an Officer in any capacity between Asst. General Manager and Manager. They should give a list of relatives, if any, working in the Bank, in any capacity.
5. The tender for the works shall remain open for acceptance for a period of 30 days.
6. The vendor shall put his full signature on all the pages of TENDER DOCUMENT with the Company's/Firm's seal.
7. The vendor shall engage his labour; procure all material and infrastructure necessary for the work. The rate quoted shall be inclusive of cost of conveyance, all leads and lifts of all materials, infrastructure, labour, and all types of taxes, octroi, & such other expenditure. The indicated quantities in the Schedule of Quantities are tentative only. The payment shall be based on the actual quantities only against bank engineer's certification.
8. Conditional tenders are liable for rejection.
9. The Defect Liability Period is 12 (Twelve months) which starts from the 14th day of work completion.
10. EARNEST MONEY DEPOSIT: Rs.NIL
11. TOTAL SECURITY DEPOSIT AND RETENTION MONEY: A further sum of 8% (Eight percent) of the gross value of each interim/ final bill shall be deducted as Retention Money which will be paid back after completion of One year from date of final bill if there are no defects in the work completed/material used.
12. The Contractor shall complete the works at the quoted rates even when the actual quantities are varying by 25% from the estimated quantities. Beyond 25% variation of actual quantities, the rates shall be settled based on prevailing market rates with proper rate analysis & the decision of the Bank shall be final in such cases.
13. Indian Standard Institute procedures will be employed for taking up measurements.
14. A. Time is the essence of the work. The Contractor should keep up the schedule and should complete the work in the stipulated time.
14. B. **A penalty of 1% of the accepted contract sum per week of delay subject to a maximum of 10% of the accepted contract sum would be levied, for the delayed period, if time schedule is not adhered to.**
14. C. If the works are not completed in the stipulated period, Bank reserves its option to terminate the contract and settle the bill for the work already executed, as certified by the Engineer-in-Charge or any other authorized official of Bank failing which bank is empowered to withdraw the Work order by giving 3 day notice through mail and can further assign the work to other bidders as per the decision of the bank.
15. **Payment terms:**
Payment will be released in Three Stages as mentioned below:

SEAL & SIGNATURE OF TENDERER

- a. 1st payment will be released after completion of 30% of the said work against Bank's Architect/Engineer's confirmation for an amount of 75% of the certified value.
 - b. 2nd payment will be released after completion of 60% of the said work against Bank's Architect/Engineer's confirmation for an amount of 75% of the certified value (netting off the amount already paid to the vendor earlier in the 1st payment)
 - c. 3rd and final payment will be released only after completion of the entire work including removal of material from the site and cleaning activity at site.
16. No Mobilizations advances, Plant & Machinery advances will be paid to the Contractor.
 17. The Bank is having right to alter/ modify the specifications, include/ delete some of the items of work from the actual tendered items. The Contractor shall do the works with alterations/ modifications/ if any & necessary cost adjustment will be made for such modified items. But no deviation from the rates tendered is allowed for rest of the items if any inclusions or deletions or made. This condition supercedes any other condition in this tender document.
 18. Compliance of necessary Labour Laws as per labour act to be ensured by the contractor. No labour below the age of 18 years shall be employed on the work.
 19. Sub-contracting of the works is not allowed.
 20. Statutory deductions like Income Tax TDS, GST TDS and Work Contract Tax etc., at the prevailing rates will be deducted at source as per the directions of the statutory bodies, from each running bill and also from the final bill.
 21. The Contractor shall be responsible and he should Indemnify the Bank for all injury/ death to the workmen, to persons, animals, things, and for any damages to the structural and/ or decorative part of the property which may arise from the operations, carelessness, accident or Neglect by himself or of any of his workmen.
 22. The Contractor should indemnify the Bank from any claims, damaged, losses on account of any accident, death, injuries suffered by his employees, agents, labourers, assignees or any other outside third parties or the Occupants. In the event of any such claims it should be at sole responsibility of the Contractor.
 23. The Contractor shall make his own arrangements for safety and security of his men and materials. Projected/ secured space to store the materials is subjected to availability and the Contractor has no right to demand this.
 24. **DETERMINATION "L1" AND AWARD OF WORKS:**
 - L1 will be decided on the basis of the lowest amount quoted in the bid as per Schedule.
 - Bank reserve the rights to negotiate the rates where it deems necessary. In the event a Bidder is not able to fulfill the contract, the Bank has right to cancel the order and to assign/distribute the order to the other selected Bidder/s after giving 3 days notice through email.
 25. Karnataka Grameena Bank will not take any responsibility for any delay due to any reason in submitting the tender documents at the specified place.
 26. Tenderer should not modify contents of this tender document under any circumstances.
 27. Vendors must be empanelled in the Bank as on the date of this RFQ/Tender are eligible to participate in the tender. All other bids from vendors not empanelled will be summarily rejected.
 28. Amount written in Grand total will be considered as the "BID PRICE" which should include the discounted competitive bid price within itself & only that amount will be considered for the calculation of L1 amount and no separate discounting should be offered after writing the Grand total.
 29. Bidder should ensure the correctness of the calculation of Grand total and the quote finalized should be double checked before the bid submission for any calculation/summation/arithmetical errors and

SEAL & SIGNATURE OF TENDERER

bank is not bound to consider any requests for corrections from the vendor after finalization of the bid.

30. Price quoted must be exclusive of GST.
31. Only contractors of eligible classes can participate in the tender. Please refer to empanelment letter for eligibility class and category. Bids from all others will be summarily rejected.

DATE:

PLACE:

SEAL & SIGNATURE OF TENDERER

3. APPROVED LIST OF MATERIALS:

01. External Emulsion : Asian (Ace)/ Nerolac/ Berger/Dulux
(Anti-flasking, Anti-fungal)
02. Oil Bound Distemper : Asian / Nerolac/ Berger/Dulux .
03. Synthetic Enamel Paint : Asian /Nerolac/Berger/Dulux
sample to be approved by the Ba
04. Cement : ACC/ Ultra Tech/Birla Shakthi
05. Primers : Asian /Nerolac/Berger/Dulux
06. Adhesive materials : Fevicol (pidilite make)
07. PVC Pipes : Finolex /Prince
08. M.S.Pipes : Tata
09. Sanitary Ware : Parry ware /Hindustan sanitary
10. Ceramic Tiles : H & R Johnson/ Bell /Kajaria/Naveen/
spartek.
11. Glazed Tiles : H & R Johnson/Bell/Kajaria/Naveen/
spartek.
12. Granite slab 20 mm thick : Edges shall be rounded. Beveled.
(Granite shall be above Rs.150/- per.sft)
13. Wood : salwood /Thali wood (imported)
(All wood must be well
Seasoned, free from knots,
Other defects, decay and
Defects due to handing
And transportation
Whatever necessary
Provided with anti
Terminate treatment)
14. Marine grade plywood : Century Ply/ Green Ply/ /Kit ply /Archi & Its
(BWF PF bounded) equivalent
15. Laminate Design, shade, Finish : AICA Sunmica, Merino, Greenlam, CenturyLaminates
& its equivalent as approved by the Bank.

SEAL & SIGNATURE OF TENDERER

16. Vinyl flooring (2mm thick) : Royal House
17. Powder coated track, ceiling : Interarch, Vista levotor, Luxalon
18. Glass : Saint Gobian / Modi Guard/ Asa hi.
19. Hinges, Tower bolts, Handles : Brass oxidized / Epoxy powder coated (Heavy duty)
20. Powder coated aluminum : Jindal make (Heavy guage 1.2mm Partitions (15.20micron 2 Step thick) electrical colour process
Using polyester powder)
21. Prelaminated boards : Novopon /Eco board (Exterior grade only)
22. Floor spring / Door closure : Everite/ Dyna
23. Fixtures : All hardware fittings & fixtures are to be Power coated. Colour, finish as Per banks Specification Godrej makes.
24. Hinges / Drawer sliders : Earl - Bilhari pvt. Ltd. Godrej
25. Tiles fixing adhesive : Algitile / Balgrout.
26. STEEL : Kamadhenu/its equivalent TMT bars.

DATE:

PLACE:

SEAL & SIGNATURE OF TENDERER

PLAN - FIRST FLOOR

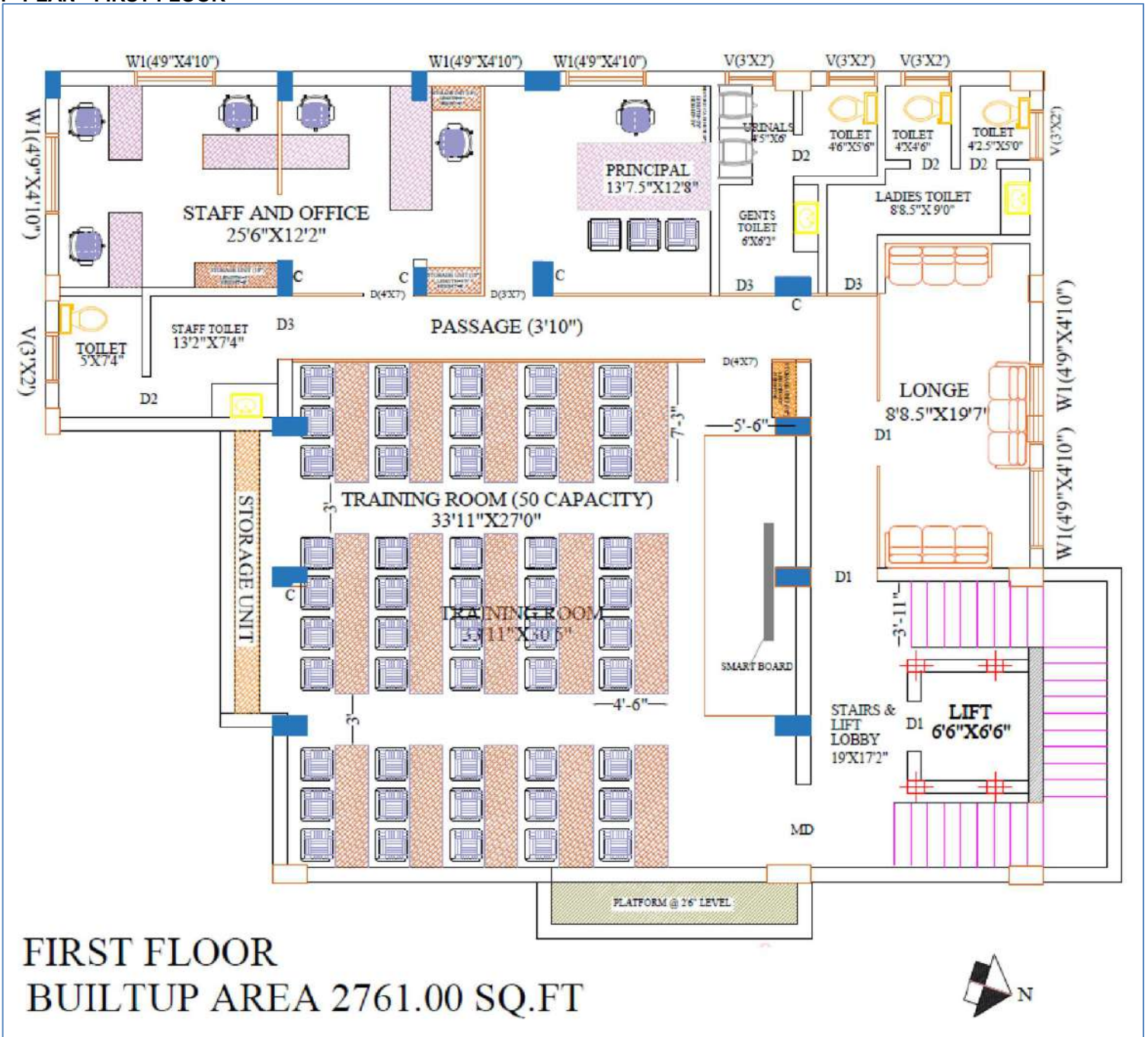

FIRST FLOOR
BUILTUP AREA 2761.00 SQ.FT

SEAL & SIGNATURE OF TENDERER

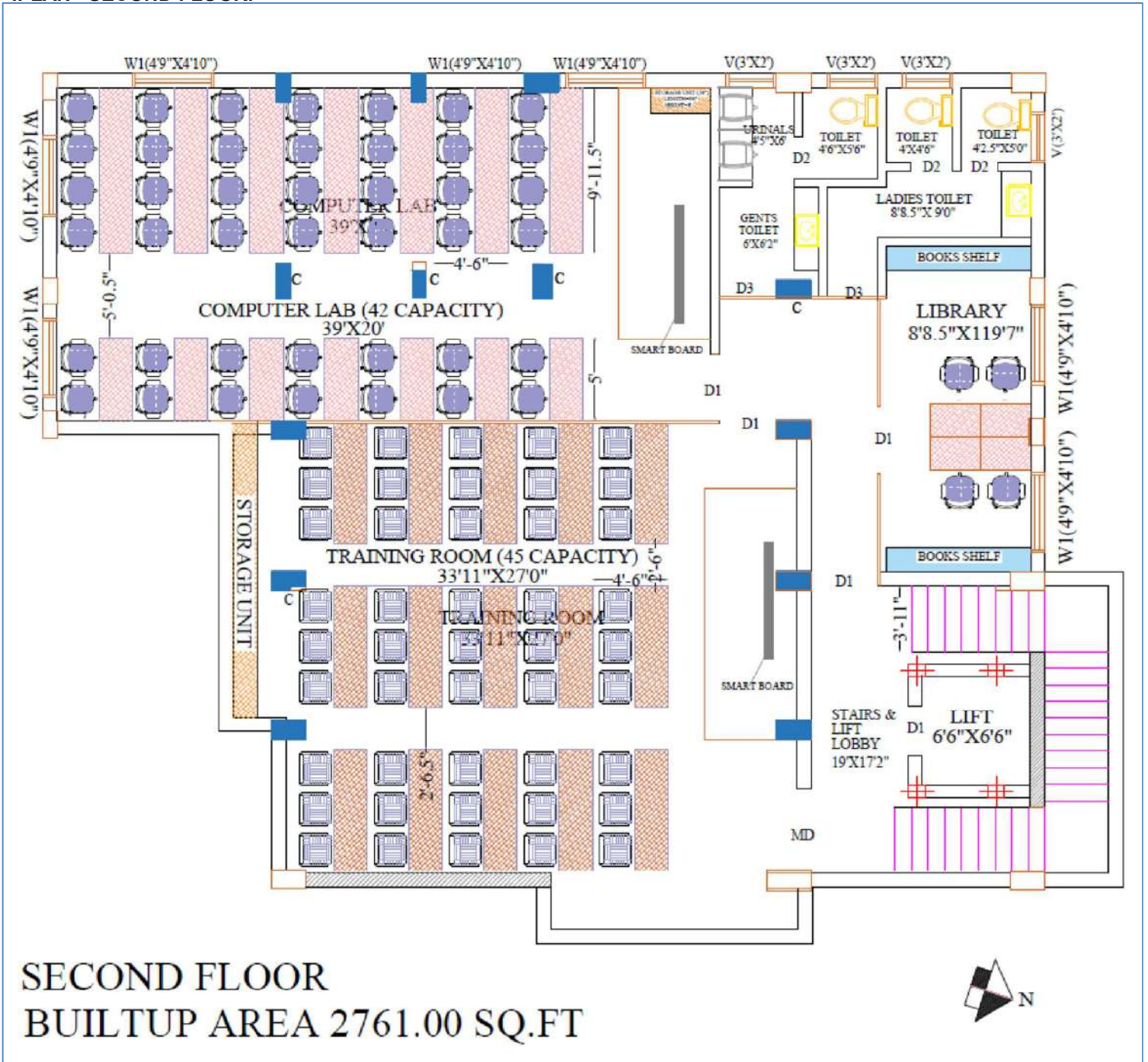

SECOND FLOOR
BUILTUP AREA 2761.00 SQ.FT

SEAL & SIGNATURE OF TENDERER



**SECTION OF DINNING TABLE
SIZE (10'X3'6")**

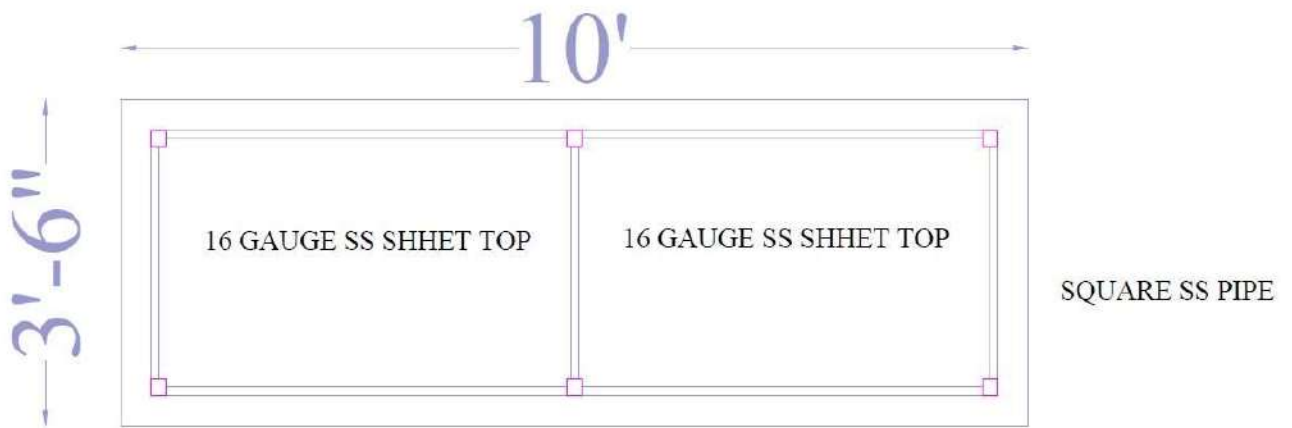

**PLAN OF DINNING TABLE
SIZE (10'X3'6")**

SEAL & SIGNATURE OF TENDERER



SECTION OF DINNING TABLE
SIZE (7'6"X3'6")

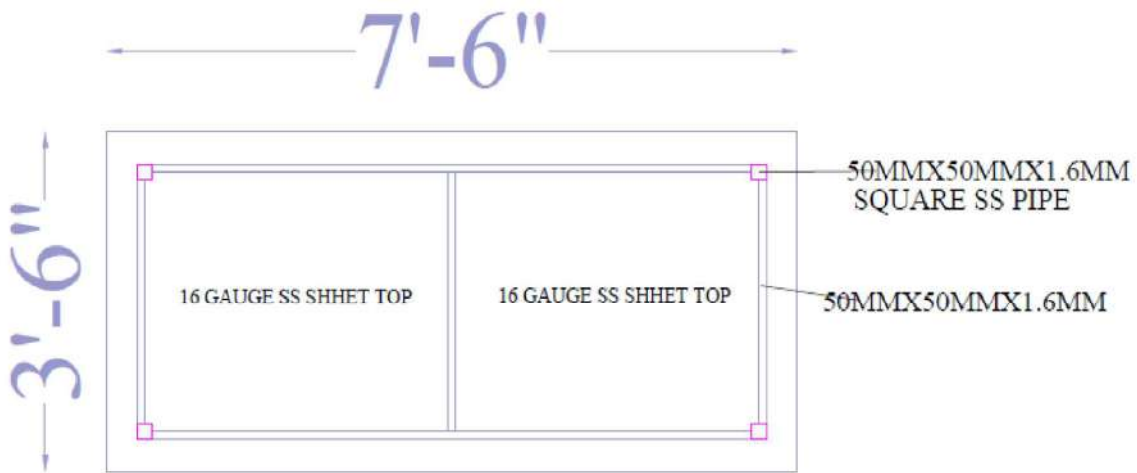

PLAN OF DINNING TABLE
SIZE (7'6"X3'6")

SEAL & SIGNATURE OF TENDERER



7" SECTION OF SS STORAGE UNIT
SIZE (6'X2'6")

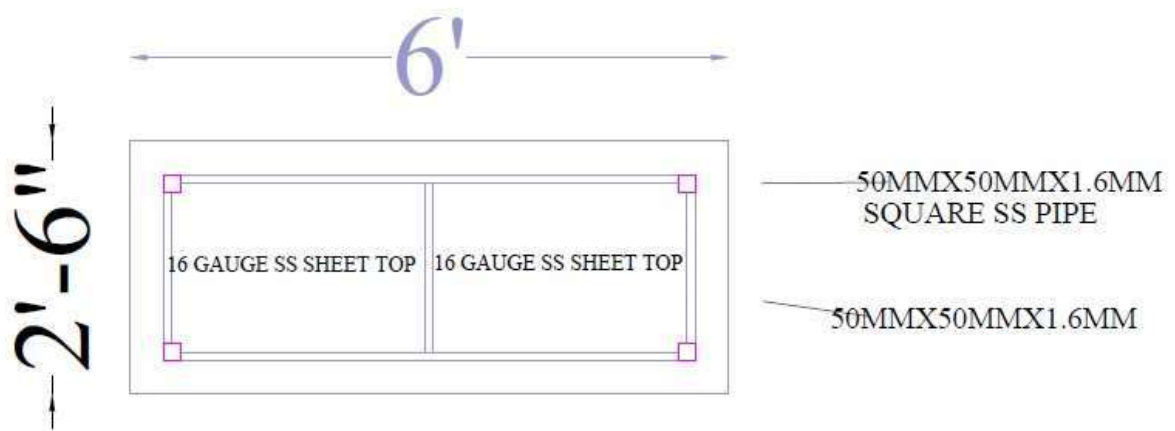

PLAN OF SS STORAGE UNIT
SIZE (6'X2'6")

SEAL & SIGNATURE OF TENDERER

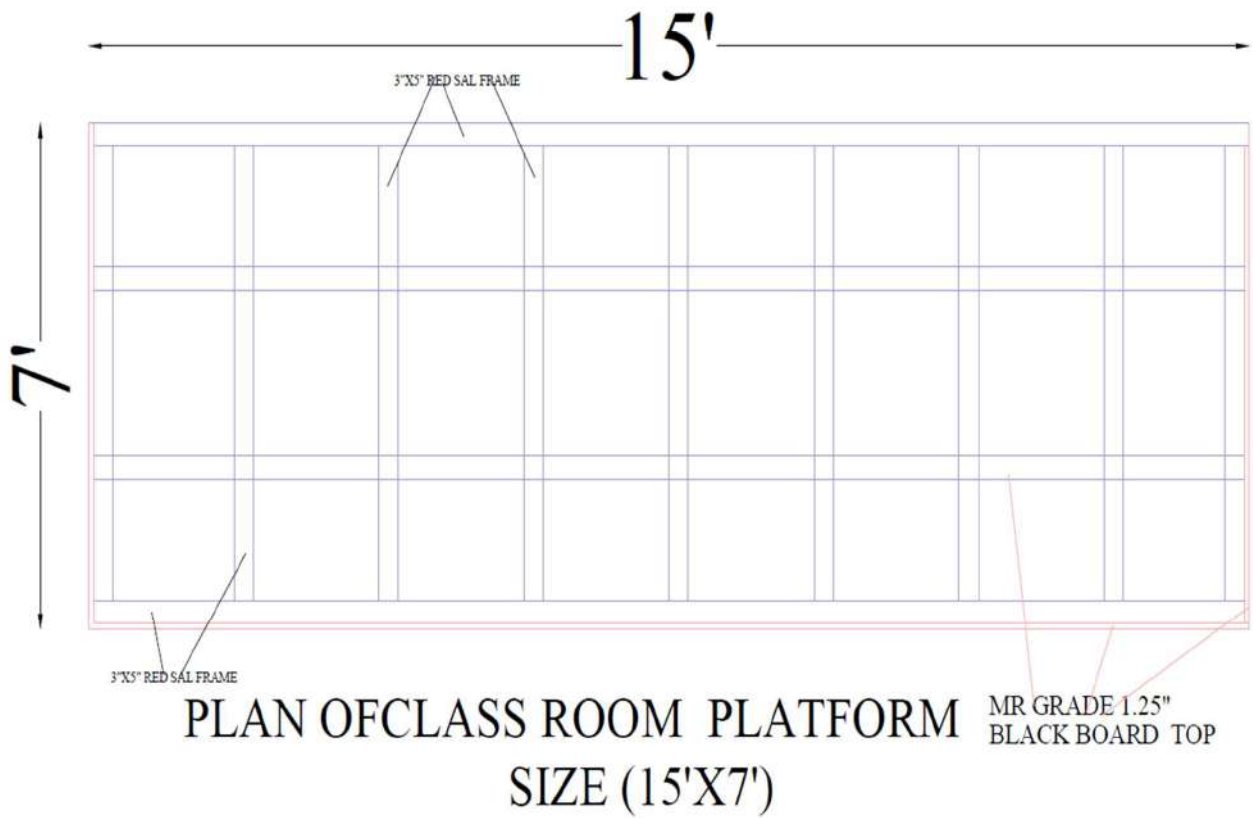
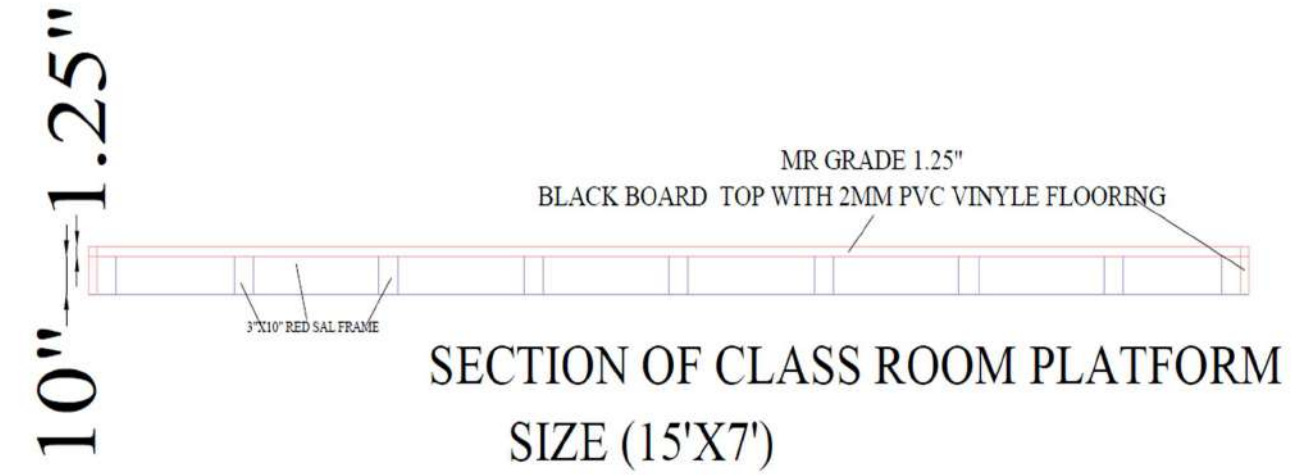

SEAL & SIGNATURE OF TENDERER

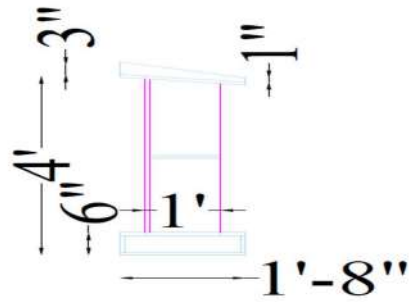

SIDE VIEW OF PODIUM
SIZE (2'6"X1'8")



TOP VIEW OF PODIUM
SIZE (2'6"X1'8")

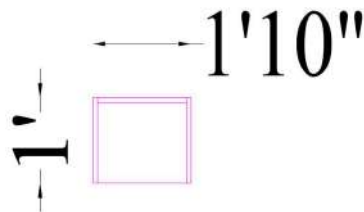

PLAN OF VERTICAL SIDES OF PODIUM
SIZE (2'6"X1'8")

**FINAL AND COMPLETE DRAWINGS WILL BE PROVIDED BY THE ARCHITECT AFTER
FINALISATION OF THE TENDER**

SEAL & SIGNATURE OF TENDERER